

DESCRIPTION

The CRYOVAC® brand AutoLoad 75 High Speed Bag Loader is a high speed, fully automatic system designed for dairy and smoked and processed meats. The AutoLoad 75 provides a smooth operation which eliminates the repetitive and labor intensive process of loading product into bags by featuring automatic advancing and opening of taped bags and a high speed belt to insert product into the opened bag. The CRYOVAC® brand packaging system including a bag loader, rotary vacuum chamber, shrink tunnel and proprietary CRYOVAC® brand shrink bags creates the ultimate finished package to protect and highlight the product.

KEY BENEFITS



Operational
Efficiency

- Machine achieves up to 45 PPM depending on product type and size
- Eliminates labor required to load product into bags
- Eliminates labor positions that are prone to injuries and repetitive motion
- Flexibility in production as able to run a variety of bag and product sizes
- Quick change tooling for various product sizes / shapes
- Full washdown with stainless steel construction
- All belts can be easily removed for cleaning without the use of tools
- Uses CRYOVAC® brand shrink bags in roll or boxed format



Product
Integrity

- Runs with CRYOVAC® brand shrink bags which provide aggressive sealant technology to protect your product from the outside environment.
- When used with CRYOVAC® brand shrink bags and vacuum packaging, protects the product's freshness, color and flavor throughout distribution



TECHNICAL DATA



MACHINE DIMENSIONS

MAX LENGTH:	240.8" (6116 mm)
WIDTH:	32.1" (816 mm)
HEIGHT:	75.2" (1910 mm)

PRODUCT DIMENSIONS

WIDTH:	2" - 9" (50 - 250 mm)
LENGTH:	Up to 21.7" (550 mm)
HEIGHT:	2" - 6" (50 - 170 mm)
WEIGHT:	0.5 - 15lbs (Up to 7kg)



CAPABILITIES

COMPRESSED AIR PRESSURE:	0.6 MPa (6 bar)
CONSUMPTION:	36 Nm 3/h



OPERATORS

NO. OF OPERATORS:	1 to monitor only
-------------------	-------------------



WEIGHT:

WEIGHT:	3100 lbs (1400 kg)
---------	--------------------



UTILITIES

ELECTRICAL:	400 - 460V +/- 10%, 3 Phase + earth, 50/60 Hz, 4 kWh max
AIR:	6 bar, 25scfm, 1/2" dia. line



SPEED

WORKING SPEED:	Up to 45 PPM depending on product application
----------------	---



BAG DETAILS

WIDTH:	5" - 14" (130 - 350 mm)
LENGTH:	8" - 23" (200 - 600 mm)

LINE LAYOUT EXAMPLE

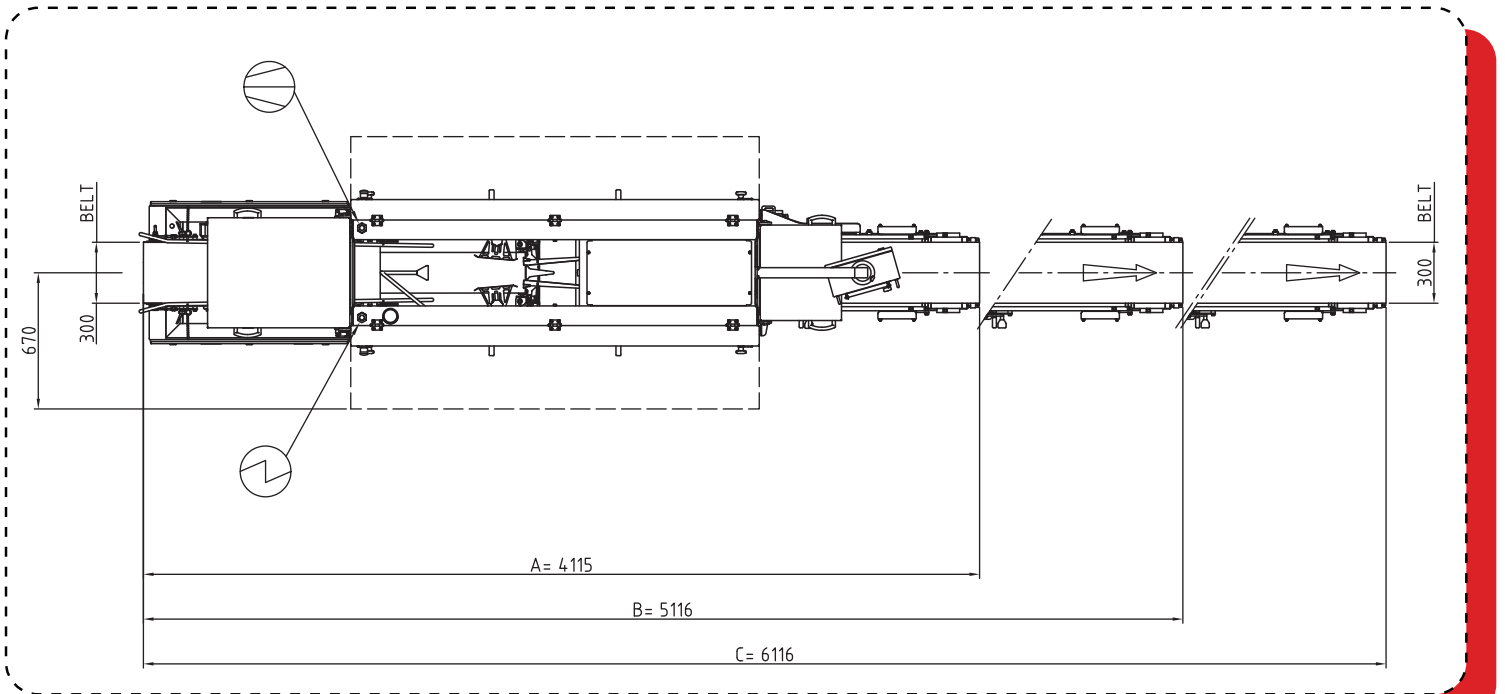

CONTACT

cryovac.na@sealedair.com