

Sealed Air®

BRAND PROTECTIVE PACKAGING

certified to
EN 15343

minimum of
40%
Post Consumer
Recycled
content

Shrink Packaging

High performance shrink films with recycled content



BENEFITS

CRYOVAC® brand CT-400 series shrink films are based on the patented Sealed Air micro-layering technology platform, providing strength and high retail appeal in non food applications. They contain a minimum of 40% PCR content which makes significant strides in sustainability.

PRODUCT INTEGRITY

- High film resistance
- High sealing characteristics prevent pack breakage
- Safe storage and handling

OPERATIONAL EFFICIENCY

Longer rolls result in:

- More packages per roll
- Increased equipment uptime
- Higher productivity with up to 50% reduction in number of roll changeovers*
- Reduced warehouse space and management for packaging supplies

BRAND EXPERIENCE

- High optics, clarity and lowest haze for improved merchandising appeal

TYPICAL APPLICATIONS

This general purpose polyolefin shrink film range provides the versatility to wrap small light weight to large heavy products, and everything in between.



Health & Beauty

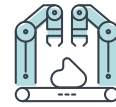

General Manufacturing



3PL



Textiles

SUSTAINABILITY



REDUCE

These films are available in thicknesses from **11 to 38 microns**, with the micro-layering contributing to **20% to 50% weight reduction** compared to conventional PE films*



REUSE

The films contain a minimum of **40%** Post Consumer Recycled content, certified to EN 15343, which establishes procedures for track and trace of recycled plastic content sourcing and use in product manufacturing.



RECYCLE

All CRYOVAC® brand CT-400 series films are recyclable in the PE waste recycling stream**

CRYOVAC® brand CT films vs Conventional Shrink films

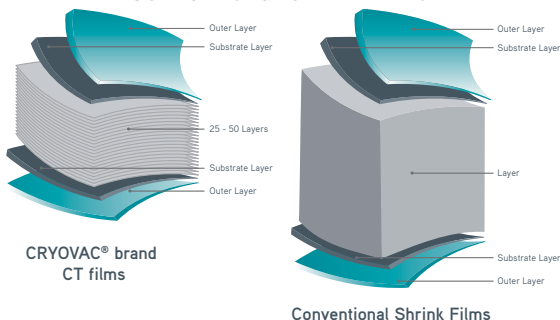

* Based on tests carried out in Sealed Air laboratories. All facilities and systems are different, so results may vary.

**Degree of recyclability of the final package depends on the specific product configuration or components intended for recycling and the scope and availability of appropriate local recycling facilities.

The information on this brochure is intended as general information and no representation or warranty is expressly or impliedly given as to its accuracy, completeness or correctness. It does not constitute part of a legal offer or contract.