

BL189 Taped Bag Loader

Description

The Cryovac® BL189 is a high speed taped bag loader designed to increase productivity and minimize down time for reloading and change-overs. The BL189 is designed for loading meat products into Cryovac® Oxygen Barrier Shrink Bags with easier access for sanitation and inspection. The BL189 features differential reels which enable easier removal of old tapes and rethreading new bags. The Sealed Air Food Care Cryovac® Packaging System including a bag loader, rotary vacuum chamber, shrink tunnel and proprietary Cryovac® Oxygen Barrier Shrink Bags creates the ultimate finished package to protect and highlight the product.

Key Benefits



OPERATIONAL
EFFICIENCY

- Eliminates excess labor required to load product into bags
- Handles various bag sizes up to 16" wide
- Minimizes down time with easy changeovers and reloading
- Compact in overall size
- Right and left hand versions available



FOOD
SAFETY

- Designed for optimal hygiene
- Utilizes Cryovac® Oxygen Barrier Bags which provide superior oxygen barrier and aggressive sealant technology to protect your product from the outside environment



SHELF LIFE
EXTENSION

- When used with Cryovac® Oxygen Barrier Bags and vacuum packaging, protects the product's freshness, color and flavor throughout distribution



BL189 Taped Bag Loader

Technical data



Machine Dimensions

Height: 34-1/2"-42-1/2" (877mm-1,080mm)
Length: 37" (940mm)
Width: 20" (508mm)



Material Dimensions:

Bag Width: 4"-16" (102 mm - 406 mm)



Weight

Weight: 240 lbs. (109 kg)
Construction: Stainless Steel



Utilities

Electrical: 115 VAC, 1 phase, 60Hz, 1AMP
Air: 60 psig, 5 scfm



Working Speed

Up to 50 ppm

Line layout example

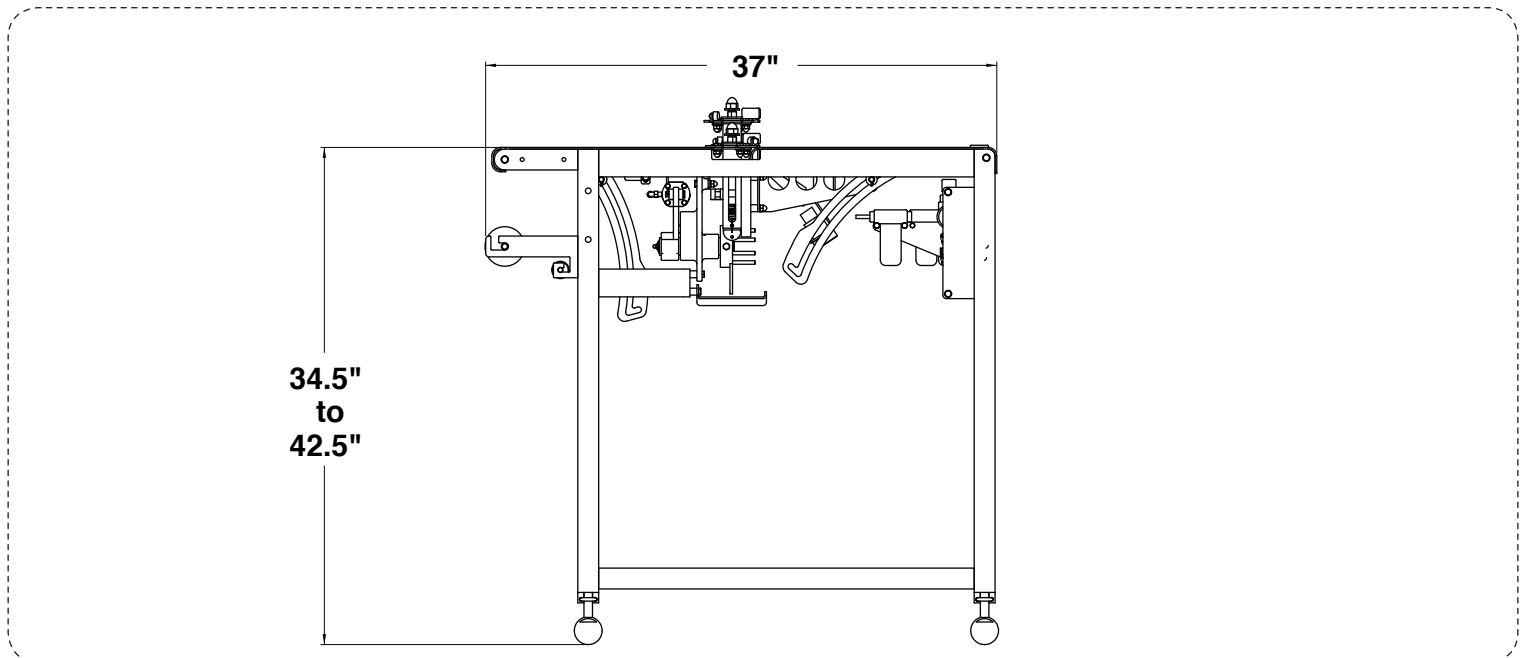

Contact

sealedair.com/foodcare